

Pump to
Proprietary Systems

3 Types of Systems

- Polystyrene
- Chambers
- Panel Block







Type of Distribution

- D-Box
- Drop Box
- Pressure Manifold
- LPP

Distribution Box





Pre-fab Pressure Manifold







Polystyrene

- Distribution can be done by any of the three methods

Distribution Box



Pre-fab Pressure Manifold





Pumping to Polystyrene is similar
to pumping to gravel

Limiting factors are usually soil and
site characteristics

Aggregate eliminates the concern
of scouring the trench bottom

Largest concern is the
protection of the system after
installation



Chambers

- Distribution is usually done with D-Boxes, Drop Boxes or Pressure Manifold

Pumping to Chambers produces a scouring problem

The flow of effluent is too fast
and damages the trench
bottom

2 GPM



5 GPM



Chamber - Serial Distribution

- Dispersal pipe in first chamber



Chamber Serial Distribution

- Distribution pipe in first chamber



Chamber – Corrugated Pipe



Infiltrator Splash Block



Infiltrator Inspection



Infiltrator High Flow Splashplate

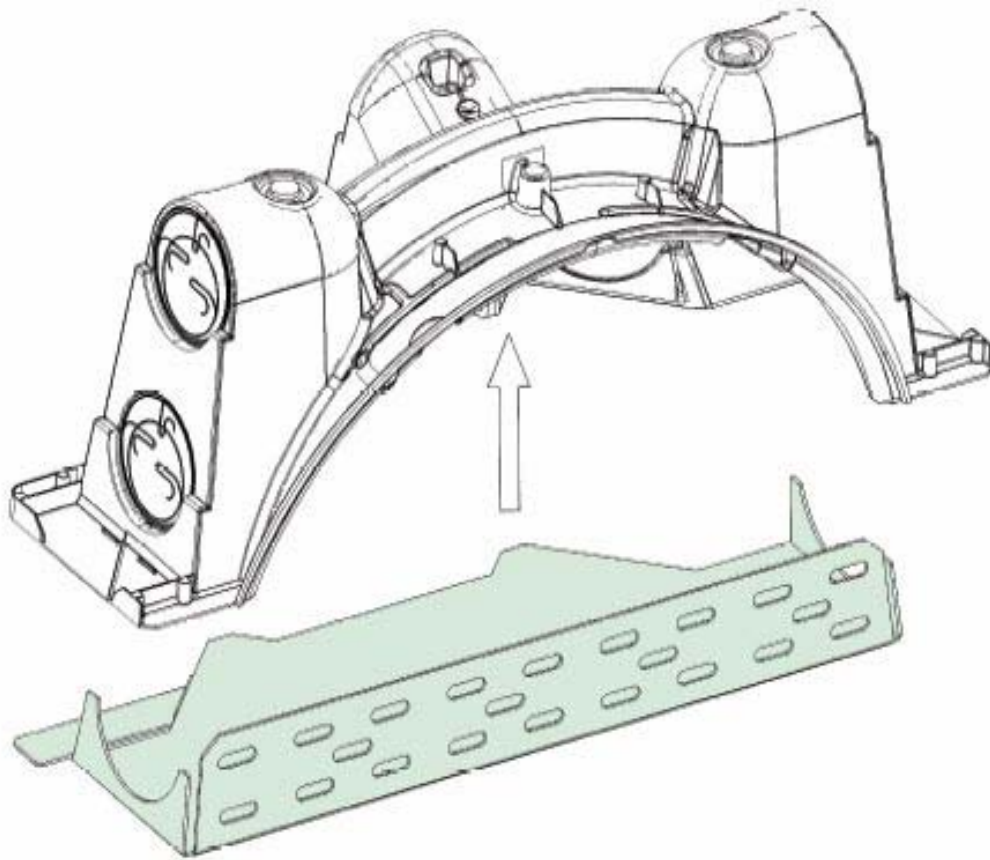

Top View

Infiltrator High Flow Splashplate





Panel Blocks

- Methods of distribution are Pressure Manifold and LPP

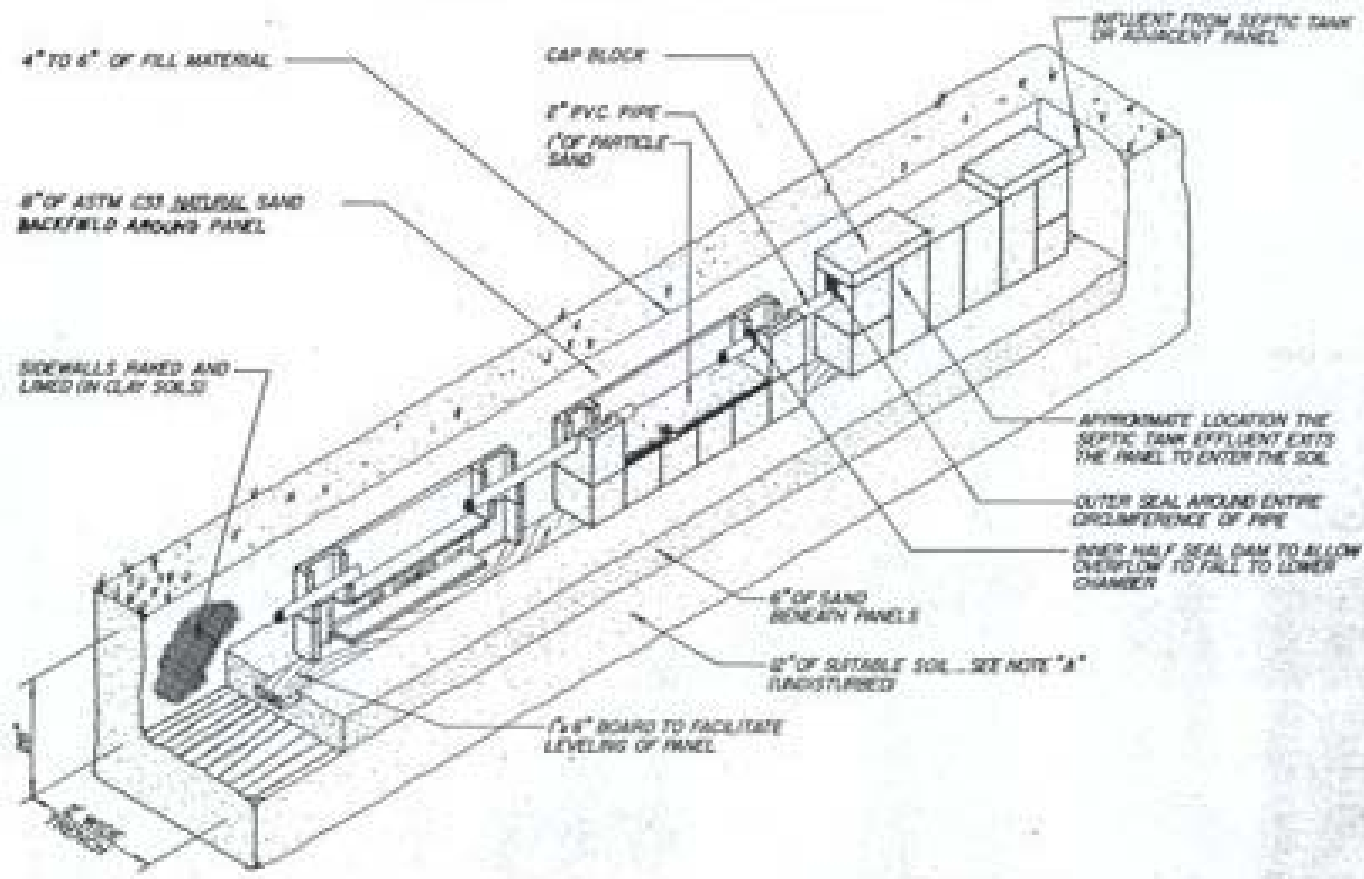

4" TO 6" OF FILL MATERIAL

CAP BLOCK

EFFLUENT FROM SEPTIC TANK OR ADJACENT PANEL

2" PVC PIPE
1" OF PARTICLE SAND

8" OF ASTM C39 NATURAL SAND BACKFILL AROUND PANEL

SIDEWALLS PAVED AND LINED (IN CLAY SOLS)

APPROXIMATE LOCATION THE SEPTIC TANK EFFLUENT EXITS THE PANEL TO ENTER THE SOIL

OUTER SEAL AROUND ENTIRE CIRCUMFERENCE OF PIPE

INNER HALF SEAL DAM TO ALLOW OVERFLOW TO FALL TO LOWER CHAMBER

8" OF SAND BENEATH PANELS

8" OF SUITABLE SOIL... SEE NOTE "A" (UNDISTURBED)

1/4" BOARD TO FACILITATE LEVELING OF PANEL

Dosing Volume of Panel Blocks

- One panel block can only hold 3.5 gallons of effluent
- Multiply the total number of panels by 3.5

A 200 linear foot system has 44
Panels

44 panels X 3.5gal/panel =
154 Gal Dosing Volume

Pre-fab Pressure Manifold



Pressure Manifold Distribution

At two foot of pressure head a manifold releases either 7.5 or 5.5 gal/min, depending on whether or not the tap is sch. 40 or 80

Concerns of Pressure Manifold Distribution in Panels

- Flow rate too much and too fast for the two inch pipe leading to the next panel causing flooding of the outer chambers
- Flow disturbs or washes out sand in the inner chamber of the first panel

Reclassifies the System

- By using a pressure manifold, the systems becomes a Type 3 instead of a Type 4
- A Certified Operator is not required with a Type 3



LPP Distribution

- A $3/16^{\text{th}}$ hole delivers .59gpm at 2 foot of pressure head
- Each panel in the entire system receives that .59 gpm

Concerns with LPP Distribution

- Proper Design
- Dosing Volume and Flow Rate calculations
- Proper Maintenance

Special Thanks

- Tom Konsler – Orange County
- Tim Johnson – T&J Panels
- Paul Penniger – S&ME

