

**North Carolina Agricultural Research Service  
North Carolina State University  
Raleigh, North Carolina**

**Notice of Naming and Release of 'Plum Regal' F<sub>1</sub> Hybrid Plum Tomato**

The North Carolina Agricultural Research Service announces the naming and release of a new fresh-market tomato hybrid cultivar, 'Plum Regal' F<sub>1</sub> hybrid plum tomato.

'Plum Regal' is the F<sub>1</sub> hybrid of NC 30P and NC 25P. It was tested as NC 05255 in replicated field trials at Fletcher, NC, from 2005-2007 and was trialed in large-scale grower plantings in North Carolina, South Carolina, and Arkansas in 2006 and 2007.

'Plum Regal' has a wide range of disease resistances. It is resistant to verticillium wilt (*Ve* gene), Fusarium wilt races 1 and 2 (*I* and *I-2* genes), tomato spotted wilt virus (*Sw-5* gene), and late blight (*Ph-3* gene). In addition, it has moderate early blight resistance derived from both parents and has exhibited less defoliation by bacterial spot than 'Plum Crimson' in research station and grower trial plantings.

'Plum Regal' was compared to 'Plum Crimson' in replicated vine-ripe harvest trials at Fletcher, NC, in 2005-2007. Marketable yields of 'Plum Regal' and 'Plum Crimson' did not differ in trials where TSWV was not a problem. Where TSWV was a problem, marketable yields of 'Plum Crimson' were greatly reduced compared to those of 'Plum Regal'. Average fruit size of 'Plum Regal' has been similar to that of 'Plum Crimson' in most trials. Percent marketable grade fruit of 'Plum Regal' has been high in all trials and has significantly exceeded that for 'Plum Crimson' in trials where TSWV occurred. 'Plum Regal' is later in maturity than 'Plum Crimson'.

'Plum Regal' has a vigorous determinate plant similar in size and other growth characteristics to that of 'Plum Crimson'. Foliage cover is heavy and provides good fruit protection. Fruit are intermediate in length to the two parents and are a desirable shape for fresh market use. Immature fruit are uniform, light green (*u* gene). Fruit pedicels are jointless (*j-2* gene). Ripe fruit are medium firm with 2-3 (mostly 3) locules and develop bright red exterior and interior color resulting from the crimson gene (*og*<sup>+</sup>) present in both parents. Fruit harvested at the mature green stage have show excellent fruit ripening and quality. Fruit are highly resistant to graywall and fruit cracking. Blossom end scars of fruit are pinpoint and non-nippled.

'Plum Regal' has exhibited a high level of late blight resistance in field trials at Waynesville, NC. In trials at Fletcher, NC, and in grower plantings, 'Plum Regal' has shown less defoliation from bacterial spot than 'Plum Crimson'.

'Plum Regal' will prove useful to growers because of its broad disease resistance and production of high yields of large fruit well adapted to market needs.

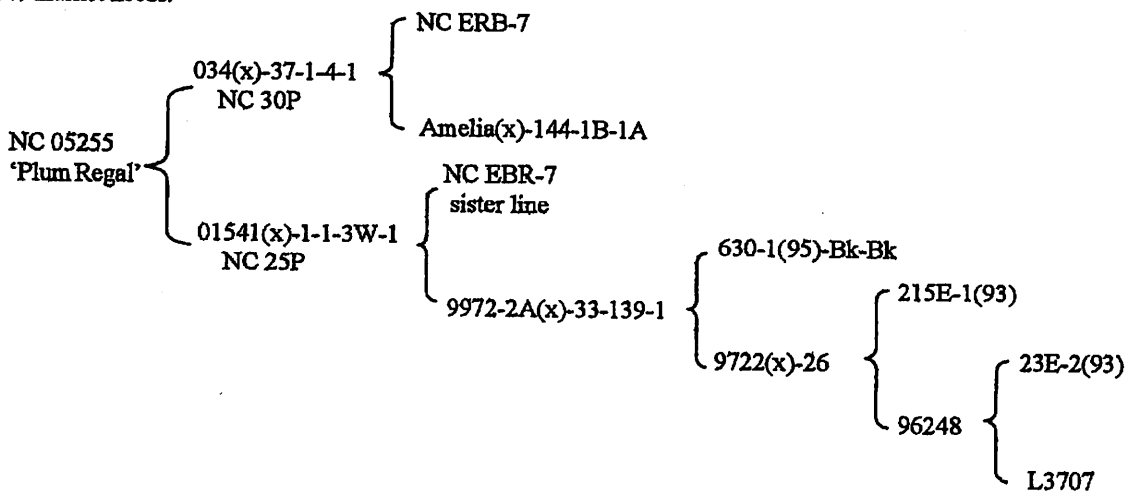

Fig. 1. Pedigrees of 'Plum Regal' F<sub>1</sub> hybrid plum tomato and its parents, NC 25P and NC 30P.

'Plum Regal' will be assigned to a selected seed company for exclusive seed production and sales. Small samples of 'Plum Regal' seed for trial purposes are available from R. G. Gardner, MHCREC, 455 Research Drive, Mills River, NC 28759; email [randy\\_gardner@ncsu.edu](mailto:randy_gardner@ncsu.edu). Additional information and pictures of the parental lines are available at the following web site: <http://www.ces.ncsu.edu/fletcher/programs/tomato/>.

  
Director, North Carolina Agricultural  
Research Service, Raleigh, NC

7-21-08  
Date